

Eloy Fire District

Amendments to the International Fire Code, 2018 Edition

Pursuant to Eloy Fire District Resolution # _____
Effective:



This material contains information which is proprietary to and copyrighted by International Code Council, Inc. The information copyrighted by the International Code Council, Inc., has been obtained and reproduced with permission. The acronym "ICC" and the ICC logo are trademarks and service marks of ICC.

ALL RIGHTS
RESERVED

CHAPTER 1 SCOPE AND ADMINISTRATION

SECTION 101 SCOPE AND GENERAL REQUIREMENTS

[A] **101.1 Title.** These regulations shall be known as the Fire Code of the Eloy Fire District hereinafter referred to as “this code.”

[A] **101.2.1 Appendices.** The following appendices are adopted as part of this code by the Eloy Fire District: Appendices B- FIRE-FLOW REQUIREMENTS FOR BUILDINGS, C- FIRE HYDRANT LOCATIONS AND DISTRIBUTION, D- FIRE APPARATUS ACCESS ROADS, E- HAZARD CATAGORIES, F- HAZARD RANKING G- CRYOGENIC FLUIDS-WEIGHT AND VOLUME EQUIVALENTS, H- HAZARDOUS MATERIALS MANAGEMENT, I- FIRE PROTECTION SYSTEMS-NON- COMPLIANT CONDITIONS, K- CONSTRUCTION REQUIREMENTS FOR EXISTING AMBULATORY CARE FACILITIES, L- REQUIREMENTS FOR FIRE FIGHTER AIR REPLENISHING SYSTEMS, N- INDOOR TRADE SHOWS AND EXHIBITIONS and O- SPECIAL EVENT GUIDELINES.

SECTION 105 PERMITS

105.7.26 Access-controlled egress doors. A construction permit is required to install or modify the connection to the fire alarm system for access-controlled egress doors in accordance with Section 1010.1.9.7

105.7.27 Delayed egress locks. A construction permit is required to install to the fire alarm system for delayed egress locks in accordance with Section 1010.1.9.8

SECTION 107 INSPECTIONS

107.5 On-site construction documents. One set of code official approved construction documents shall be on the job site for each inspection. Failure to have approved construction documents on site shall result in canceling the inspection and is subject to assessment of a fee in accordance with the adopted fee schedule of the Eloy Fire District.

SECTION 112 STOP WORK ORDER

[A] **112.4 Failure to comply.** Any person who shall continue any work after having been served with a stop work order, except such work as that person is directed to perform to remove a violation or unsafe condition, shall be liable to a fine of not less than \$250.00 dollars or more than \$2500.00 dollars per occurrence.

CHAPTER 2 DEFINITONS

SECTION 202 GENERAL DEFINITIONS

FIRE FLOW. The flow rate of a water supply, measured at 20 psi residual pressure that is available for firefighting.

FORCED AIR CURTAIN DESTRUCTOR. A forced air pit incinerator is utilized for the purpose of disposal of waste vegetative debris.

PREEMPTION DEVICE. A listed and approved electronic device that receives a signal compatible with transmitters on emergency vehicles and that is used to automatically open or close fire apparatus access gates and all traffic control devices.

STANDBY PERSONNEL. Qualified fire service personnel, approved by the Fire Chief. When utilized, the number required shall be as directed by the Fire Chief. Charges for utilization shall be calculated by the city approved fee schedule.

OCCUPANCY CLASSIFICATIONS

Institutional Group I-1

This occupancy shall include buildings, structures or portions thereof for more than 10 persons who reside on a 24 hour basis in a supervised environment and receive custodial care. The persons receiving care are capable of self-preservation. This Group shall include, but not be limited to, the following:

- Alcohol and drug centers
- Assisted living facilities
- Congregate care facilities
- Convalescent facilities
- Group homes

- Halfway houses
- Residential board and custodial care facilities
- Social rehabilitation facilities
- Five or fewer persons receiving care. A facility such as the above with five or fewer persons receiving such care shall be classified as Group R-3 and shall comply with the requirements of section 310.5.1 of the International Building Code as amended.
- Six to ten persons receiving care. A facility such as above, housing not fewer than six and not more than 10 persons receiving such care, shall be classified as Group R-4.

Institutional Group I-2. This occupancy shall include buildings and structures used for medical care on a 24-hour basis for more than five persons who are incapable of self-preservation. This group shall include, but not be limited to the following:

- Foster care facilities
- Detoxification facilities
- Hospitals
- Nursing homes
- Psychiatric hospitals
- Five or fewer persons receiving care. A facility such as the above with five or fewer persons receiving such care shall be classified as Group R-3 and shall comply with the International Residential Code provided an automatic sprinkler system is installed in accordance with Section 903.3.1.3 or with Section P2904 of the International Residential Code requirements of section 310.5.1 of the International Building Code as amended.

Institutional Group I-4, day care facilities.

This group shall include buildings and structures occupied by more than five persons of any age who receive custodial care for fewer than 24 hours per day by persons other than parents or guardians, relatives by blood, marriage or adoption, and in a place other than the home of the person cared for. This group shall include, but not be limited to, the following:

- Adult day care

Classification as Group E. A child day care facility that provides care for more than five but no more than 100 children 2 1/2 years or less of age, where the rooms in which the children are cared for are located on a level of exit discharge serving such rooms and each of these child care rooms has an exit door directly to the exterior, shall be classified as Group E.

Within a place of religious worship. Rooms and spaces within places of religious worship providing such care during religious functions shall be classified as part of the primary occupancy.

- Five or fewer persons receiving care. A facility having six or fewer persons receiving custodial care shall be classified as part of the primary occupancy.
- Five or fewer persons receiving care in a dwelling unit. A facility such as the above within a dwelling unit and having five six or fewer persons receiving custodial care shall be classified as a Group R-3 occupancy or shall comply with the International Residential Code.

Residential Group R. Residential Group R includes, among others, the use of a building or structure, or a portion thereof, for sleeping purposes when not classified as an Institutional Group I or when not regulated by the International Residential Code. Assisted living and similar facilities shall meet the requirements of the Arizona Department of Health Services Title 9, Chapter 10, and Article 7 as required in addition to the requirements in this code. These may be known as “group care homes” or “care facilities”.

Residential Group R-3. Residential occupancies where the occupants are primarily permanent in nature and not classified as Group R-1, R-2, R-4 or I, including:

- Buildings that do not contain more than two dwelling units
- Boarding houses with 6 or fewer occupants
- Care facilities that provide accommodations for five or fewer persons receiving care
- Congregate living facilities with 6 or fewer occupants.
 - To include both *Transient* and *Nontransient* facilities.

Care facilities within a dwelling. Care facilities for five or fewer persons receiving care, that are within a single-family dwelling are permitted to comply with the International Residential Code and R-3 Residential Care/Assisted Living Facilities occupancies in existing structures with five or fewer occupants excluding staff shall meet the following requirements:

1. Smoke detectors shall be installed in all livable areas.
2. Posted evacuation map and emergency procedures.
3. Portable fire extinguishers in accordance to Section 906.1.

An automatic sprinkler system may be installed in accordance with Section 903.3.1.3 or with Section P2904 of the International Residential Code.

Residential Group R-4. This occupancy shall include care facilities in buildings, structures or portions thereof for more than five but not more than 10 persons, excluding staff, who reside on a 24-hour basis in a supervised residential environment and receive custodial care. This group shall include, but not be limited to, the following:

- Alcohol and drug centers
- Assisted living facilities
- Congregate care facilities
- Convalescent facilities
- Group homes
- Halfway houses
- Residential board and custodial care facilities

- Social rehabilitation facilities

Group R-4 occupancies shall meet the requirements for construction as defined for Group R-3, except as otherwise provided for in the *International Building Code*.

R-4 care facilities that have residents that are incapable of self-preservation shall be subject to all State licensing requirements applicable for such occupancies.

CHAPTER 3 GENERAL REQUIREMENTS

SECTION 307 OPEN BURNING, RECREATIONAL FIRES AND PORTABLE OUTDOOR FIREPLACES

307.2.1 Authorization. No fire shall be kindled or any weeds or debris burned on any premises, street, alley vacant lot or agricultural land within the city limits without first obtaining a permit from the Pinal County Department of Air Pollution Control and verbal notification to the Eloy Fire District.

CHAPTER 4 EMERGENCY PLANNING AND PREPAREDNESS NO AMENDMENTS

CHAPTER 5 FIRE SERVICE FEATURES

SECTION 503 FIRE APPARATUS ACCESS ROADS

503.1 Where required. Fire apparatus access roads shall be provided and maintained in accordance with Sections 503.1.1 through 503.1.3 and Appendix D.

503.1.4. Temporary Fire Department access. Temporary Fire Department access shall comply with Fire Department requirements. No construction on any project may proceed until such time as the fire protection plan for the project has been approved by the fire code official.

503.6 Security gates. The installation of security gates across a fire apparatus access road shall be approved by the fire chief. Where automatic security gates are installed, they shall have a preemption device and/or a key override switch for entry and exit. The security gates and the emergency operation shall be maintained operational at all times.

1. The gate when fully opened shall provide a minimum clear width of 20 feet. The turning radius for fire department apparatus shall not be affected by the

placement of the arm or gate.

SECTION 507 FIRE PROTECTION WATER SUPPLIES

507.3 Fire flow. Fire flow requirements for buildings or portions of buildings and facilities shall be determined by an approved method and in accordance with Appendix B as amended. The Fire Chief may require an approved independent third party individual or firm to conduct a fire flow test prior to issuance of a Certificate of Occupancy.

507.3.1 Fire Flow Verification. The Fire Chief may require all new buildings or structures to provide fire flow verification according to the requirements in Appendix B as amended. Verification shall be conducted by an approved separate third party certifying the fire flow data.

507.5.1.2 Fire Protection Water Supply. The water system is required to be looped with a minimum of two separate connections under the following conditions:

1. Dead end water line exceeds 100' for 6" lines or 400' for 8" lines.
2. Water lines serve a building over 52,000 sq. ft. (40,000 sq. ft. when used for any amount of high-piled storage).
3. Water lines serve a building over two stories.
4. Water lines serve more than one commercial building.
5. Water lines serve over 30 single-family residential units.
6. Water lines serve a Group "H" occupancy.
7. As otherwise required by the fire marshal.

Where two water connections are required, they shall be placed a distance apart equal to not less than one half of the length of the maximum overall diagonal dimension of the property or area to be served, measured in a straight line between the water connections. Where two water connections are required, they shall be made to separate water lines where possible.

507.5.2.1 Water distribution system failure notification. Each water service provider serving areas within the city, whether municipal or private, shall notify the Fire Department of any failure in their water distribution system, hydrant repair, main breaks, pump failures, or other interruptions of water supply that may affect water supply for fire control purposes as soon as possible in writing. A 30 day written notification is required for any fire line service that is to be discontinued due to financial lack of financial payment.

507.5.2.2 Out of service hydrants: Any hydrant that is out of service shall have an out of service ring located on the 4 inch supply and shall remain in place until the hydrant is operational and approved by the Fire Chief.

507.5.7 Separate water supply. Water supply for sprinkler systems shall not be combined with the domestic water supply.

**CHAPTER 6
BUILDING SERVICES AND SYSTEMS
NO AMENDMENTS**

**CHAPTER 7
FIRE AND SMOKE PROTECTION FEATURES
NO AMENDMENT**

**CHAPTER 8
INTERIOR FINISH, DECORATIVE MATERIALS AND FURNISHINGS
NO AMENDMENTS**

**CHAPTER 9
FIRE PROTECTION AND LIFE SAFETY SYSTEMS**

**SECTION 903
AUTOMATIC SPRINKLER SYSTEMS**

903.2.1.1 Group A-1. An automatic sprinkler system shall be provided for Group A-1 occupancies where one of the following conditions exists:

1. The fire area exceeds 5000 square feet.
2. The fire area has an occupant load of 300 or more.
3. The fire area is located on a floor other than a level of exit discharge serving such occupancies.
4. The fire area contains a multi-theater complex.

903.2.1.3 Group A-3. An automatic sprinkler system shall be provided for Group A-3 occupancies where one of the following conditions exists:

1. The fire area exceeds 5,000 square feet.
2. The fire area has an occupant load of 300 or more.
3. The fire area is located on a floor other than a level of exit discharge serving such occupancies.

903.2.1.4 Group A-4. An automatic sprinkler system shall be provided for Group A-4 occupancies where one of the following conditions exists:

1. The fire area exceeds 5,000 square feet
2. The fire area has an occupant load of 300 or more.
3. The fire area is located on a floor other than a level of exit discharge serving such occupancies.

903.2.3 Group E. An automatic sprinkler system shall be provided for Group E occupancies as follows:

1. Throughout all Group E fire areas greater than 5,000 square feet in area.
2. Throughout every portion of educational buildings below the lowest level of exit discharge serving that portion of the building.

Exception: An automatic sprinkler system is not required in any area below

the lowest level of exit discharge serving that area where every classroom throughout the building has at least one exterior exit door at ground level.

903.2.4 Group F-1/F-2. An automatic sprinkler system shall be provided throughout all buildings containing a Group F-1/F-2 occupancy where one of the following conditions exists:

1. A Group F-1/F-2 fire area exceeds 5,000 square feet.
2. A Group F-1/F-2 fire area is located more than three stories above grade plane.
3. The combined area of all Group F-1/F-2 fire areas on all floors, including any mezzanines, exceeds 5,000 square feet.
4. A Group F-1/F-2 occupancy used for the manufacture of upholstered furniture or mattresses exceeds 2,500 square feet.

903.2.6 Group I. An automatic sprinkler system shall be provided throughout buildings with a Group I fire area.

Exceptions:

- An automatic sprinkler system installed in accordance with Section 903.3.1.2 shall be permitted in Group I-1 facilities.
- An automatic sprinkler system installed in accordance with Section 903.3.1.3 shall be allowed in Group I-1 facilities when in compliance with all of the following:
 - A hydraulic design information sign is located on the system riser; 2.2. Exception 1 of Section 903.4 is not applied; and Systems shall be maintained in accordance with the requirements of Section 903.3.1.2 and shall be installed on the entire floor where care is provided and all floors between the level of care and the level of exit discharge, all floors below the level of exit discharge, other than areas classified as an open parking garage.
- An automatic sprinkler system is not required where day care facilities are at the level of exit discharge and where every room where care is provided has at least one exterior exit door.
- In buildings where Group I-4 day care is provided on levels other than the level of exit discharge, an automatic sprinkler system in accordance with Section 903.3.1.1 shall be installed on the entire floor where care is provided and all floors between the level of care and the level of exit discharge, all floors below the level of exit discharge, other than areas classified as an open parking garage.

903.2.7 Group M and B occupancies. An automatic sprinkler system shall be provided throughout buildings containing a Group M or B occupancy where one of the following conditions exists:

1. A Group M/B fire area exceeds 5,000 square feet.
2. A Group M/B fire area is located more than three stories above grade plane.
3. The combined area of all Group M/B fire areas on all floors, including any

mezzanines, exceeds 5,000 square feet.

4. A Group M/B occupancy used for the display and sale of upholstered furniture or mattresses exceeds 5,000 square feet.

903.2.8 Group R. An automatic sprinkler system installed in accordance with Section 903.3 shall be provided throughout all buildings with a Group R fire area.

Exceptions:

1. R-4 occupancies, legally existing as of March 30, 2008, shall not be required to install an automatic sprinkler system unless there is an upward change in the number of occupants the facility is licensed to care for.
2. State Licensed residential care/assisted living facilities in which all of the care recipients are capable of self-preservation and responding to an emergency situation without assistance from another person.
3. State licensed residential care/assisted living facilities, legally existing as of March 30, 2008, in which some or all of the care recipients are incapable of self-preservation or of responding to an emergency situation without assistance from another person.
4. R-3 occupancies, and one- and two-family dwellings, built under the requirements of the International Residential Code with less than 5000 Square feet of floor area. Unenclosed decks, patios, and similar building areas, as well as attached garages, shall not be included in determining the 5000 sq. ft. area

903.2.9 Group S-1 and S-2. An automatic sprinkler system shall be provided throughout all buildings containing Group S-1 occupancy where one of the following conditions exists:

1. Where a Group S-1 or S-2 fire area exceeds 5,000 square feet;
2. Where a Group S-1 or S-2 fire area is located more than three stories above grade; or
3. Where the combined area of all Group S-1 or S-2 fire areas on all floors, including mezzanines, exceeds 10,000 square feet.

903.2.9.1 Repair Garages. An automatic sprinkler system shall be provided throughout all buildings used as repair garages in accordance with the International Building Code, as follows:

1. Buildings two or more stories in height, including basements, with a fire area containing a repair garage exceeding 5,000 square feet.
2. One-story buildings with a fire area containing a repair garage exceeding 5,000 square feet.
3. Buildings with a repair garage servicing vehicles parked in the basement.

903.2.9.2 Bulk storage of tires. Buildings and structures where the area for the storage of tires exceeds 5,000 square feet shall be equipped throughout with an automatic sprinkler system in accordance with Section 903.3.1.

903.6.2 Existing buildings with fire walls. Any addition, alteration or repair causing any portion of the building or structure divided by a fire wall or partition to exceed 5,000 square feet shall be required to conform to the requirements of Section 903.2 for that fire area.

903.7.1 Protection and security of sprinkler systems. All fire sprinkler risers shall be secured and protected from the environment by being located inside the building or structure with a direct exterior access.

SECTION 907 FIRE ALARM AND DETECTION SYSTEMS

907.10.1 Interior Tenant Notification. Interior Tenant Notification shall be provided when monitoring of the fire sprinkler system is provided. Group R occupancies are exempt from this requirement.

- Shell Buildings: 1 (one) horn strobe shall be installed and operational within the interior space prior to final. When demising walls are present, 1 (one) horn-strobe shall be installed for each space. Multistory buildings shall require a minimum of 1 (one) horn-strobe per level.
- Tenant Improvements (Shell build-outs): 1 (one) horn-strobe shall be provided for each individual tenant. When a common area is provided serving multiple tenants, a minimum of 1 (one) horn-strobe in the common area shall be provided.

These requirements may be increased based on occupancy type or at the discretion of the fire chief.

CHAPTER 10 MEANS OF EGRESS NO AMENDMENTS

CHAPTER 11 CONSTRUCTION REQUIREMENTS FOR EXISTING BUILDINGS

SECTION 1103 FIRE SAFETY REQUIREMENTS FOR EXISTING BUILDINGS

1103.5.2 Group I-2. An automatic sprinkler system shall be provided throughout existing Group I-2 fire areas. The sprinkler system shall be provided throughout the floor where the Group I-2 occupancy is located, and in all floors between the Group I-2 occupancy and the level of exit discharge.

CHAPTER 12 ENERGY SYSTEMS NO AMENDMENTS

**CHAPTER 13-19
ENERGY SYSTEMS RESERVED
NO AMENDMENTS**

**CHAPTER 20
AVIATION FACILITIES
NO AMENDMENTS**

**CHAPTER 21
DRY CLEANING
NO AMENDMENTS**

**CHAPTER 22
COMBUSTIBLE DUST-PRODUCING OPERATIONS
NO AMENDMENTS**

**CHAPTER 23
MOTOR FUEL-DISPENSING FACILITIES AND REPAIR GARAGES
NO AMENDMENTS**

**CHAPTER 24
FLAMMABLE FINISHES
NO AMENDMENTS**

**CHAPTER 25
FRUIT AND CROP RIPENING
NO AMENDMENTS**

**CHAPTER 26
FUMIGATION AND INSECTICIDAL FOGGING
NO AMENDMENTS**

**CHAPTER 27
SEMICONDUCTOR FABRICATION FACILITIES
NO AMENDMENTS**

**CHAPTER 28
LUMBER YARDS AND AGRO-INDUSTRIAL, SOLID BIOMASS AND
WOODWORKING FACILITIES
NO AMENDMENTS**

**CHAPTER 29
MANUFACTURE OF ORGANIC COATINGS
NO AMENDMENTS**

**CHAPTER 30
INDUSTRIAL OVENS
NO AMENDMENTS**

**CHAPTER 31
TENTS, TEMPORARY SPECIAL EVENT STRUCTURES AND OTHER MEMBRANE
STRUCTURES**

3103.8.2 Location. Tents or membrane structures shall not be located within 10 feet (6096 mm) of *lot lines*, buildings, other tents or membrane structures, parked vehicles or internal combustion engines. For the purpose of determining required distances, support ropes and guy wires shall be considered as part of the temporary membrane structure or tent.

3106.5 Cooking appliances or devices. Outdoor assembly events with concession stands or booths using cooking appliances or devices shall comply with Sections 3106.5.3 and Appendix O **Special Event Guidelines**.

**CHAPTER 32
HIGH-PILED COMBUSTIBLE STORAGE
NO AMENDMENTS**

**CHAPTER 33
FIRE SAFETY DURING CONSTRUCTION AND DEMOLITIONS
NO AMENDMENTS**

**CHAPTER 34
TIRE REBUILDING AND TIRE STORAGE
NO AMENDMENTS**

**CHAPTER 35
WELDING AND OTHER HOT WORK
NO AMENDMENTS**

**CHAPTER 36
MARINAS
NO AMENDMENTS**

**CHAPTER 37
COMBUSTIBLE FIBERS
NO AMENDMENTS**

**CHAPTER 38
HIGHER EDUCATION LABORATORIES
NO AMENDMENTS**

**CHAPTER 39
PROCESSING AND EXTRACTION FACILITIES
NO AMENDMENTS**

**CHAPTER 40-49 Reserved
NO AMENDMENTS**

**CHAPTER 50
HAZARDOUS MATERIALS – GENERAL PROVISIONS
NO AMENDMENTS**

**CHAPTER 51
AEROSOLS
NO AMENDMENTS**

**CHAPTER 52
RESERVED
NO AMENDMENTS**

**CHAPTER 53
COMPRESSED GASES
NO AMENDMENTS**

**CHAPTER 54
CORROSIVE MATERIALS
NO AMENDMENTS**

**CHAPTER 55
CRYOGENIC FLUIDS
NO AMENDMENTS**

**CHAPTER 56
EXPLOSIVES AND FIREWORKS
NO AMENDMENTS**

**CHAPTER 57
FLAMMABLE AND COMBUSTIBLE LIQUIDS
NO AMENDMENTS**

**CHAPTER 58
FLAMMABLE GASES AND FLAMMABLE CRYOGENIC FLUIDS
NO AMENDMENTS**

**CHAPTER 59
FLAMMABLE SOLIDS
NO AMENDMENTS**

**CHAPTER 60
HIGHLY TOXIC AND TOXIC MATERIALS
NO AMENDMENTS**

**CHAPTER 61
LIQUEFIED PETROLEUM GASES
NO AMENDMENTS**

**CHAPTER 62
ORGANIC PEROXIDES
NO AMENDMENTS**

**CHAPTER 63
OXIDIZERS, OXIDIZING GASES AND OXIDIZING CRYOGENIC FLUIDS
NO AMENDMENTS**

**CHAPTER 64
PYROPHORIC MATERIALS
NO AMENDMENTS**

**CHAPTER 65
PYROXYLIN (CELLULOSE NITRATE) PLASTICS
NO AMENDMENTS**

**CHAPTER 66
UNSTABLE (REACTIVE) MATERIALS
NO AMENDMENTS**

**CHAPTER 67
WATER-REACTIVE SOLIDS AND LIQUIDS
NO AMENDMENTS**

**CHAPTERS 68 through 79
RESERVED
NO AMENDMENTS**

**REFERENCED
STANDARDS NO
AMENDMENTS**

**APPENDICES C, D, E, F, G, H, I, L, N
NO AMENDMENTS**

**APPENDIX
B
FIRE FLOW REQUIREMENTS FOR
BUILDINGS**

Delete and replace section B105.2 as follows:

B105.2 Buildings other than one- and two-family dwellings, Group R-3 and R-4 buildings and townhouses. The minimum fire-flow and flow duration for buildings other than one- and two-family dwellings, Group R-3 and R-4 buildings and townhouses shall be as specified in Tables B105.2 and B105.1(2).

**APPENDIX O SPECIAL
EVENT GUIDELINES**

AO101 Seating and/or Site Plans for Indoor or Outdoor Events. Detailed plans will eliminate most of the problems that occur when a Fire Inspector does an inspection. Promoters with events that require a permit must attach a scaled or detailed floor or site plan to the permit application. A plan will assist the Fire Department in determining if the event will be safe and in compliance with codes. The plans **must show** the following (provide what is applicable).

1. The location and width of all exit doors, aisles in large exhibitor areas, and the main event aisle ways.
2. The location, size, and identification number of exhibits, booths, cooking booths, and other displays spaces.
3. The location and **size** of propane (LPG) containers.
4. The location and width of the fire lanes and the location of fire hydrants.
5. The distance from tents to property lines, fences, and structures.
6. The location of fire extinguishers, exit lighting, and exit signs

AO102 Tents and Canopies: Tents exceeding 200 square feet and canopies exceeding 400 square feet require permits.

Construction documents. A detailed site and floor plan for tents, canopies, air-supported, air-inflated or tensioned membrane structures with an occupant load of 50 or more shall be provided with each application for approval. The floor plan shall indicate details of the means of egress, seating capacity,

arrangement of the seating and location and type of any heating, food preparation and electrical equipment. The site plan shall indicate distances to lot lines, buildings, other temporary structures and parked vehicles. The temporary structure shall be no closer than 20 feet to the aforementioned (some exceptions may apply).

Access. Access points to the site, fire lanes and fire hydrants shall be indicated on the site plan. Fire lanes shall be a minimum 20 feet in width and maintained free of obstructions. Fire hydrants shall have a minimum, unobstructed clearance of 20 feet on all sides with clear access to one side from a fire lane.

Inspections. Required prior to occupancy/use.

AO102.1 Fire Safety Requirements

AO102.1.1 Flame-resistant treatment. Before a permit or approval is granted, the owner or agent shall file with the code official a certificate executed by an approved testing laboratory, certifying that the tents, air-supported, air-inflated or tensioned membrane structures and their appurtenances, sidewalls, drops and tops of temporary membrane structures, canopies, tarpaulins, floor coverings, bunting, combustible decorative materials and effects, including sawdust when used on floors or passageways, shall be composed of flame-resistant material or shall be treated with a flame retardant in an approved manner and meet the requirements for flame resistance as determined in accordance with NFPA 701, and that such flame resistance is effective for the period specified by the permit.

AO102.1.2 Label. Temporary membrane structures, tents or canopies shall have a permanently affixed label bearing the identification of size and fabric or material type.

AO102.1.3 Certification. An affidavit or affirmation shall be submitted to the code official and a copy retained on the premises on which the tent or air-supported structure is located. The affidavit shall attest to the following information relative to the flame resistance of the fabric.

1. Names and address of the owners of the tent or air-supported structure.
2. Date the fabric was last treated with flame-resistant solution.
3. Trade name or kind of chemical used in treatment
4. Name of person or firm treating the material.
5. Name of testing agency and test standard by which the fabric was tested.

AO102.2 Combustible materials. The areas within and adjacent to the tent or air-supported structure, shall be maintained clear of all combustible materials or

vegetation that could create a fire hazard within 20 feet from the structure. Combustible trash shall be removed at least once a day from the structure during the period the structure is occupied by the public.

AO102.3 Smoking. Smoking shall not be permitted in tents or air-supported structures. Approved “No Smoking” signs shall be conspicuously posted.

AO102.4 Open or exposed flame. Open flame or other devices emitting flame, fire or heat or any flammable or combustible liquids, gas, charcoal or other cooking device are permitted provided they meet the standards listed in the next section.

AO102.5 Spot lighting. Spot or effect lighting shall only be by electricity, and all combustible construction located within 6 feet of such equipment shall be protected with approved noncombustible insulation not less than 9.25 inches thick.

AO102.6 Vegetation removal. Combustible vegetation shall be removed from the area occupied by a tent, air-supported, air-inflated or tensioned membrane structure, temporary membrane structure or canopy and from areas within 30 feet of such structures.

AO102.7 Waste material. The floor surface inside tents, air-supported, air-inflated or tensioned membrane structures, temporary membrane structures or canopies and the grounds outside and within a 30-foot perimeter shall be kept clear of combustible waste. Such waste shall be stored in approved containers until removed from the premises.

AO102.8 Portable fire extinguishers. Fire extinguishers with a minimum 2A:10B:C classification are required. The number depends on the size of the structure.

A103 Concession stands/food vendors: Cooking Equipment and Food Warming Devices. Listed below are approved cooking/warming appliances:

1. Microwave and electric ovens
2. Electric steam tables
3. Electric cook top griddles
4. Electric single well deep fat fryer or wok

Propane/butane use is ***prohibited*** inside tents.

AO103.1 Extinguisher Required. A 2A:10BC fire extinguisher shall be available

in each cooking area and a “**Type K**” extinguisher if deep fat frying or Woks are used.

AO103.2 Tents and Canopies, Outdoor Use for *Cooking Booths*. Cooking booths must have 10' of clearance on two sides.

AO103.2.1 Appliances with open-flame cooking tops, fryers, skillet frying, and WOKS cannot be located in a tent or under a canopy.

Exceptions Woks, and open flame cooking may occur in a booth constructed as follows. (Refer to drawing examples at the end of this Appendix O).

1. Use non-combustible siding and roofing materials to construct the main booth or
2. The main booth has a metal hood that vents out the top of the booth and the hood perimeter extends a minimum of 6" beyond all edges of cooking appliances.

AO103.2.1.1 When using Woks or when deep fat frying, each booth must have a “**Type K**” fire extinguisher. Booths with other types of cooking must have a 40BC type fire extinguisher. Fire extinguishers must have a tag attached showing the fire extinguisher was serviced within the last twelve months.

AO103.2.2 Propane or flammable liquids must not be stored inside.

AO103.2.3 Propane cylinders less than 500 water gallons in size must be **at least 10' from the booth**. Propane cylinders 500 water gallons in size must be **at least 25' from any booth**.

AO103.2.4 Appliances with open-flame cooking tops, fryers, skillet frying, and WOKS cannot be located in a tent or under a canopy.

Open-flame cook tops are burners with visible flames that heat or make contact with Woks, skillets, pans, etc. A secondary hard lid covering the appliances, made of fire-resistive material, and separated by a minimum of 3 feet behind the main booth and from adjacent tents or canopies can be used. **AO104 Exhibit Booth and Display Requirements**

AO104.1 Travel distance. The travel distance within a booth or a vendor’s exhibit area to an accessible exit aisle shall not exceed 50 ft.

AO104.2 Construction. Booths constructed of combustible materials, foam, wood (< 2” x 4”), cloth, and/or ***plastic tarps shall be fire retardant.***

AO104.3 Exit in Exhibits. Booth, table and display areas shall be clearly marked so exhibits do not occupy or extend into exits and aisles. ***Do not block exit doors or fire alarm horns and pull stations, and fire extinguishers.***

AO105 Exits and Aisle Use. All exits shall be available for use by men, women, and children at all times and especially during a fire, or other emergency. Aisles and exits shown on the approved floor or site plans shall be kept clean, clear, and free from obstructions. Easels, signs, displays, and other objects shall not encroach into aisles and exits from the booth, display, or stage areas.

AO106 Fire Extinguishers. Each event shall have portable extinguishers, the **minimum size** must be a U.L classification **2A 10BC** and cooking areas using oil must have a **40BC**, and when deep fat frying or using Woks a “**Type K**” is required. Extinguishers shall have a **current service tag** (serviced within the last 12 months), and be visible and accessible in the booth at all times.

AO107 Use of Propane at Special Events.

AO107.1 Indoor Use. The use of propane inside of buildings is **prohibited**.

AO107.1.2 Outdoor Use. Propane cylinders less than 500 water gallons in size must be at least 10' from any structure. Propane cylinders 500 water gallons in size must be at least 25' from the structure (not allowed under building eaves). Propane cylinders must be set on a firm foundation or be adequately secured and protected from potential damage.

AO108 Electrical Cords, Protection, and Use. Household rated (small thin type) extension cords, spliced cords or homemade receptacles are NOT permitted.

AO108.1 Protection. Cords subjected to foot or equipment traffic shall be protected from damage.

AO108.1.2. Cords 3/8” or less in diameter shall be covered with hard plastic “office cord covers” or an approved alternate method.

AO108.1.3. Cords equal to or larger than 3/8” in diameter shall use a plywood ramp style cover, or an approved alternate method.

All **cord covers** must be secured in place using tape, nails, or other methods.

AO109 Bouncy Houses/Inflatable Membrane Structures. Shall meet the following and manufacturer’s installation and use instructions for staking/stability and safe operation.

AO109.1 Door operation. During high winds exceeding 5 miles per hour the use of doors in air-supported structures shall be controlled to avoid excessive air loss. Doors shall not be left open. *Because the design pressure is critical in maintaining the structural integrity of an air-supported structure, doors must not be kept open for extended periods. Controls on door usage help prevent excessive losses of internal pressure. When large openings are necessary, such as for vehicular traffic, vestibules help avoid excessive pressure loss.*

AO109.2 Fabric envelope design and construction. Air-supported and air-inflated structures shall have the design and construction of the fabric envelope and the method of anchoring in accordance with Architectural Fabric

Structures Institute ASI77.

AO109.3 Blowers. An air-supported structure used as a place of assembly shall be furnished with not less than two blowers, each of which has adequate Capacity to maintain full inflation pressure with normal leakage. The design of the blower shall be so as to provide integral limiting pressure at the design pressure specified by the manufacturer.

AO109.4 Auxiliary power. Places of public assembly for more than 200 persons shall be furnished with either a fully automatic auxiliary engine-generator set capable of powering one blower continuously for 4 hours, or a supplementary blower powered by an internal combustion engine which shall be automatic in operation. Power cords shall be secured so as not to provide a tripping hazard or be located where vehicle or other traffic may damage the cord, causing a fire or injury risk as per AO108.1

**AO Figure
1
Booth Construction
Examples**

The following Examples of cooking booth construction or configurations that would be approved for use. The size, design or appearance is not being represented by the drawing only the concept of a cooking booth that will be safe and in compliance with the International Fire Code

Option 1: Open Flame Cooking with no frying or deep fat frying.

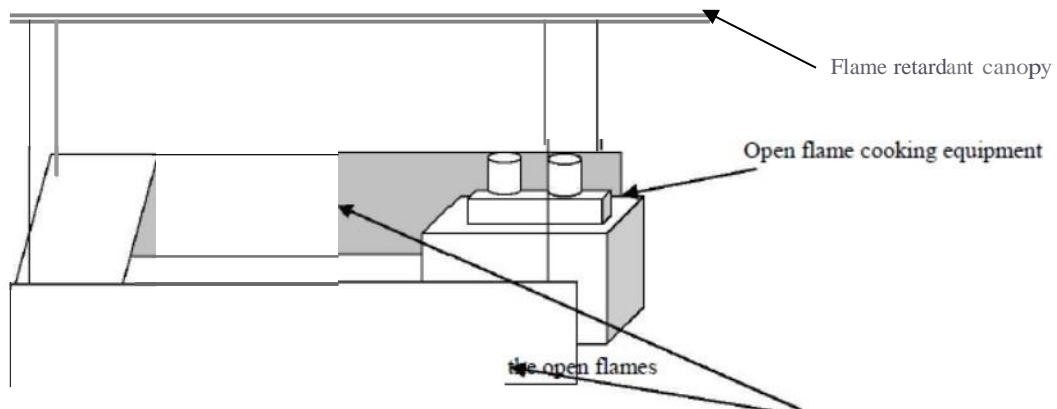

Non-Combustible material for booth siding that extends 6" above the open flames

Option 2: Open Flame Cooking with no frying or deep fat frying.

Flame retardant canopy

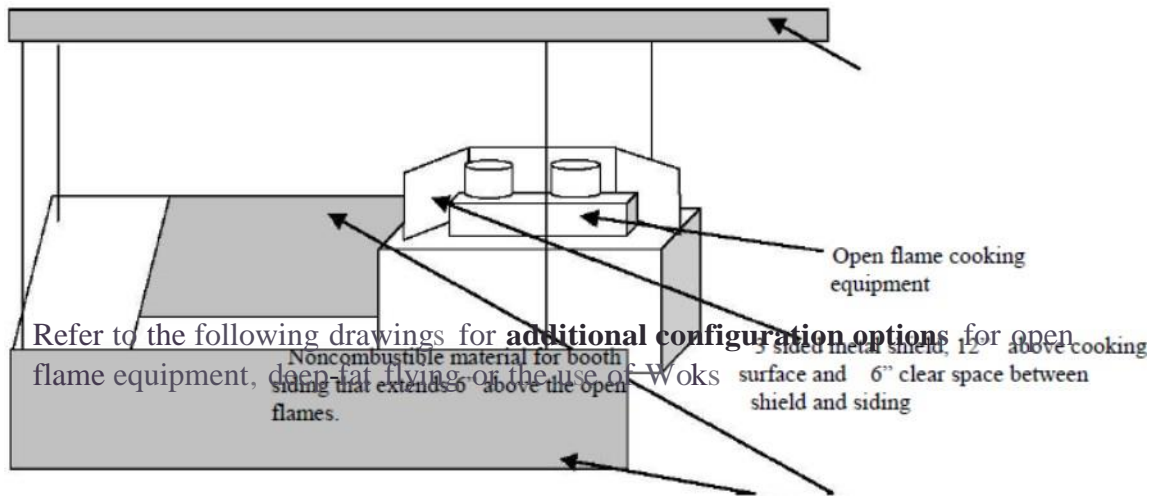

Option 3: Open-Flame Cooking or deep fat frying.

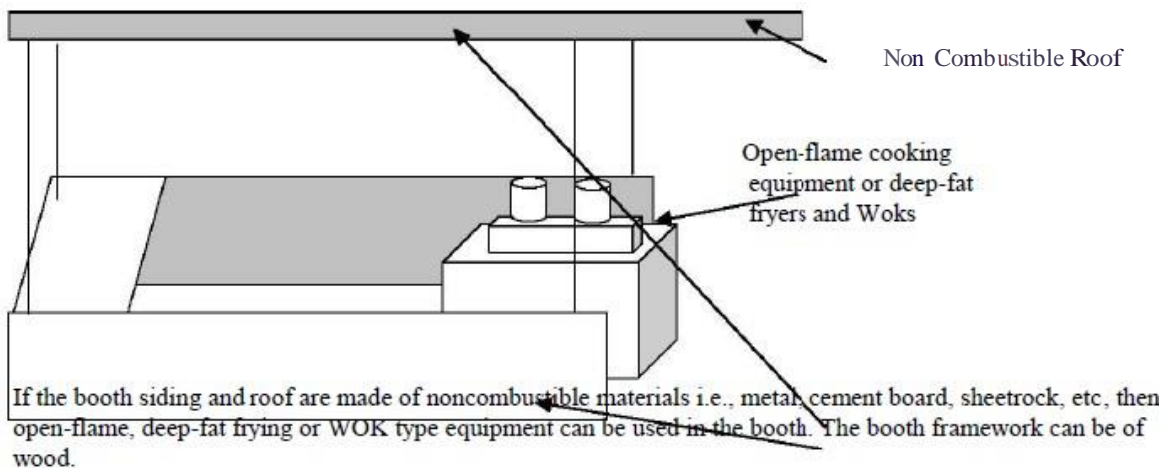

Option 4: Open-Flame Cooking or deep fat frying and Woks.

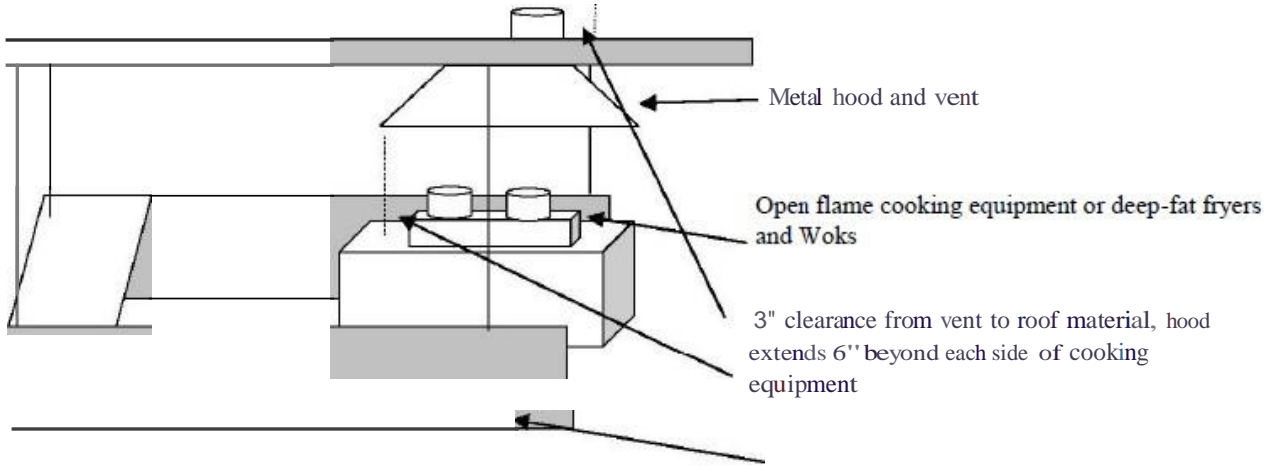

- A booth can be made of fire retardant treated combustible material e.g., wood, fabric, etc, if:
1. It has a metal hood that vents a couple feet above the roof
 2. The hood extends at least 6" beyond the perimeter of the cooking equipment.
 3. The hood vent has at least 3" clearance from the roofing material unless a double-walled vent is used.
 4. 12" clear space must be maintained between the cooking equipment and the sides of the booth unless the shield is used from Option 2 then 6" is permitted

Option 5: Open-Flame Cooking or deep fat frying and Woks.

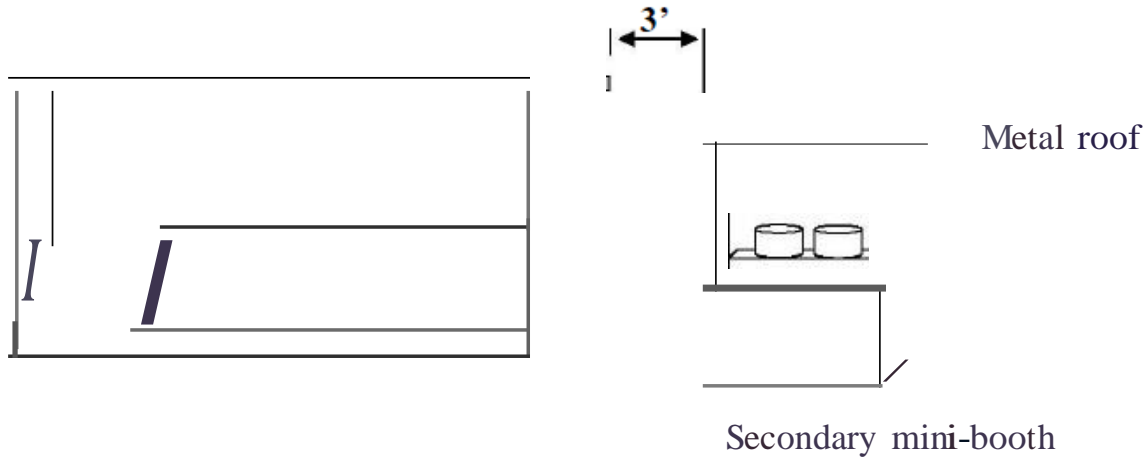

A booth made of fire retardant treated combustible material e.g., (wood, fabric, etc, but without a hood and vent cannot have open-flame, deep-fat fryers or WOK) equipment under the booth roof covering or near its sides.

That the cooking equipment can be used if it is separated at least 3' from the sides and roof of the main booth and adjacent booths. The roof covering for the secondary mini-booth must be metal if located within 3' to 5' of the primary booth. Even if it is further away, it is not recommended to use fabric or other combustibles for that roof covering.